

REV.	ECN NO.	DATE

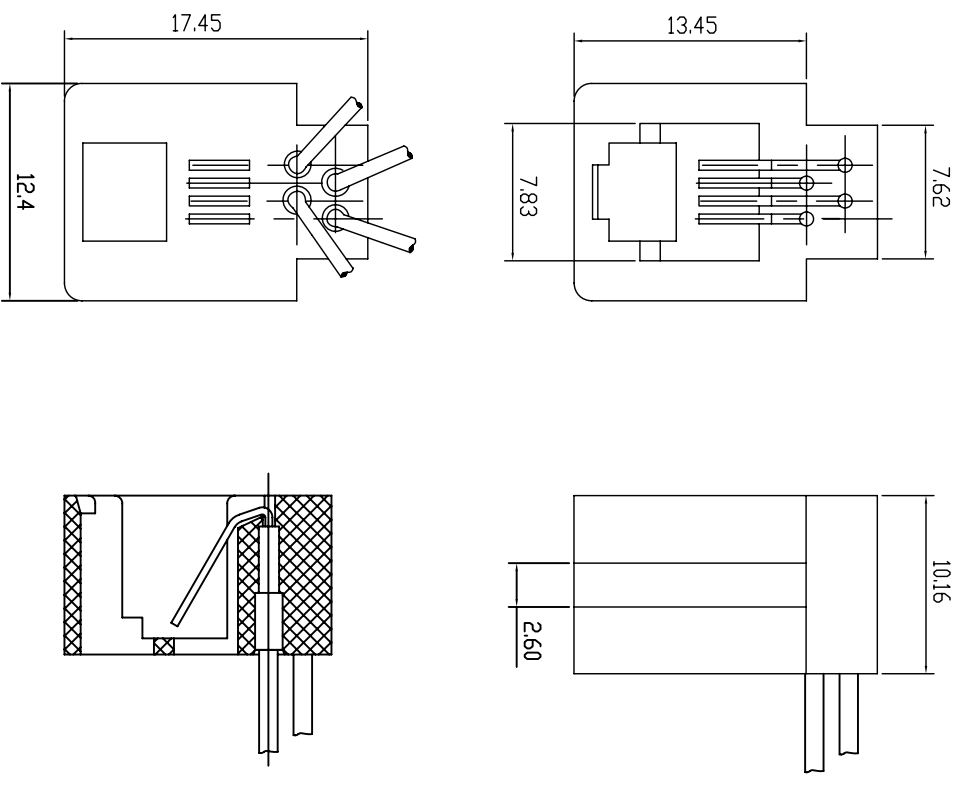

SPECIFICATION NOTES:

ELECTRICAL:

1. VOLTAGE RATING: 125 VAC RMS
2. CURRENT RATING: 1.5 AMP
3. CONTACT RESISTANCE: 20mΩ MAX.
4. INSULATION RESISTANCE: 1000MΩ MIN. AT 500V DC.
5. DIELECTRIC STRENGTH: 1000 V AC OR 1500V DC RMS AT 0.5mA 50 Hz / 60 Hz FOR 1 MINUTE

MECHANICAL:

1. HOUSING: ABS
 2. CONTACT MATERIAL: DIA. PHOSPHOR BRONZE $\phi=0.46\text{MM}$
 3. PLATING: GOLD PLATING AT CONTACT AREA, NICKEL 30 μ " MIN. OVER ALL
 4. OPERATING LIFE: 750 CYCLES MIN.
 5. MATING/UNMATING FORCE: 30N/3.06KG MAX.
 6. RETENTION STRENGTH: 50N MIN. FOR 60S \pm 5S
- ENVIRONMENTAL:
1. STORAGE: 0°C TO +70°C RELATIVE HUMIDITY < 80%
 2. GUARANTEE PERIOD: 6 MONTHS
 3. OPERATION: 0°C TO +70°C

ROHS COMPLIANT



温州意华连接器股份有限公司
WENZHOU YIHUA CONNECTOR CO., LTD

THIRD ANGLE PROJECTION	SCALE	UNIT	CUSTOMER	MODEL NO.
	A4	mm	N/A	N/A
SIZE	1:1	mm	MODEL NO.	N/A

TOLERANCES	Material:
0~15 ±0.15	SEE TABLE
15~30 ±0.20	Finish:
30~50 ±0.25	SEE TABLE
50~ ±0.30	SHEET 1 OF 1
ANGLES: ±1°	Approved:

Material:	Designed:
SEE TABLE	Checked:
Finish:	Approved:
SEE TABLE	
SHEET 1 OF 1	

NAME:	DWG NO.
616M 4P4C	20151014-2
PART NO.	REV.

1 2 3 4